

# Whistle Set Up Diagram

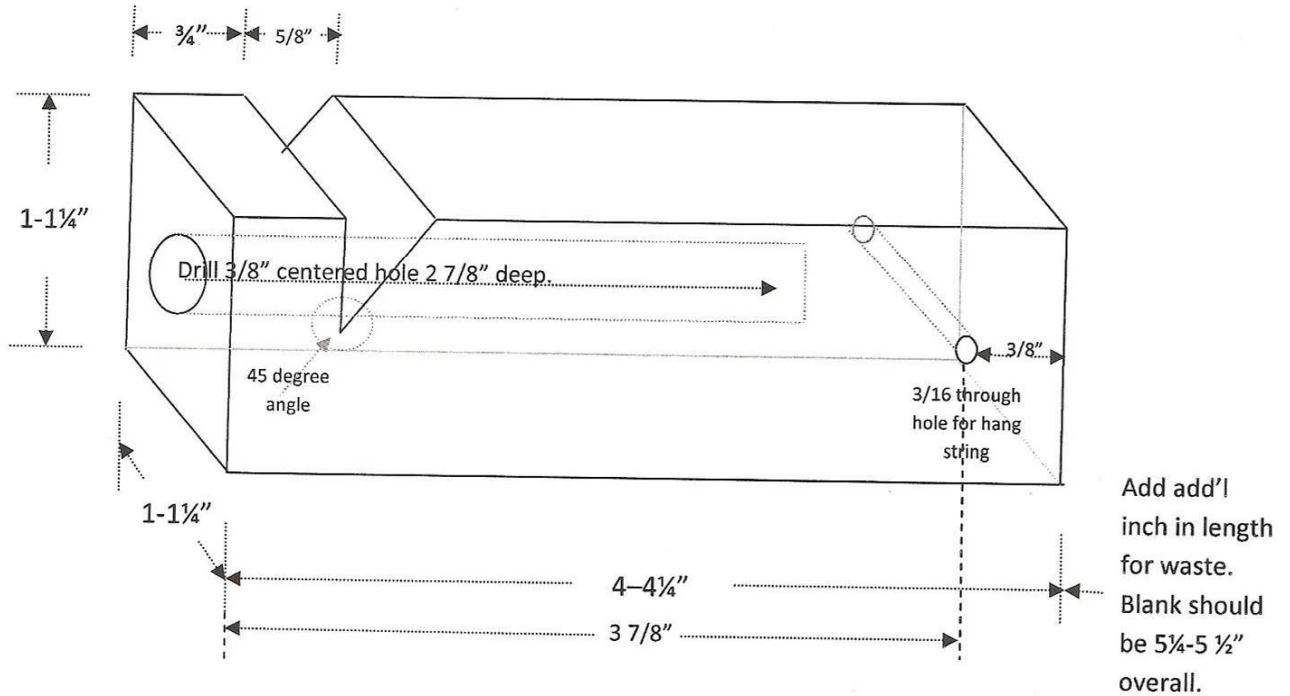

Complete all drilling and band saw cuts before turning.  
 Take care to avoid chip outs during turning: sharp tools, light cuts.  
 Whistle tone can be improved by widening the slant cut at the top.

## Completed Whistle Shape

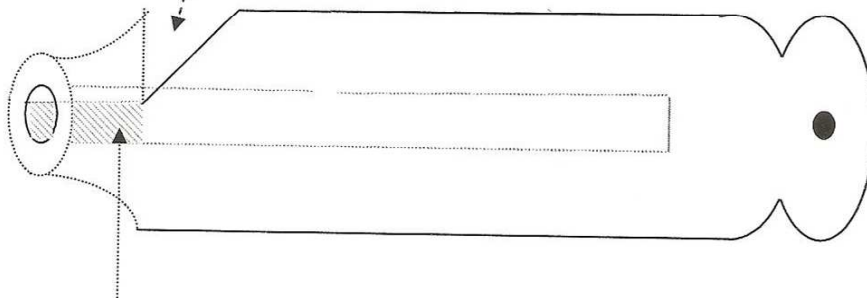

3/8" dowel sanded flat on top and glued in place. This channels the air past the "V" cut causing the whistling sound. Before gluing, test whistle for correct dowel placement.